

UNITED STATES  
DEPARTMENT OF  
COMMERCE  
PUBLICATION



# FISHERY FACTS-4

U. S. DEPARTMENT OF COMMERCE  
National Oceanic and Atmospheric Administration  
National Marine Fisheries Service

A black and white photograph of a fisherman on a boat. The fisherman is wearing a plaid shirt and a cap, and is smiling while holding a large lobster. In the background, a large wooden beam is suspended by ropes, and a lobster trap is hanging from it. The sea is visible in the lower part of the image.

## inshore lobster fishing

JOHN T. EVERETT

SEATTLE, WA  
October 1972

NMFS Extension Publication

The major responsibilities of the National Marine Fisheries Service (NMFS) are to monitor and assess the abundance and geographic distribution of fishery resources, to understand and predict fluctuations in the quantity and distribution of these resources, and to establish levels for optimum use of the resources. NMFS is also charged with the development and implementation of policies for managing national fishing grounds, development and enforcement of domestic fisheries regulations, surveillance of foreign fishing off United States coastal waters, and the development and enforcement of international fishery agreements and policies. NMFS also assists the fishing industry through marketing service and economic analysis programs, and mortgage insurance and vessel construction subsidies. It collects, analyses, and publishes statistics on various phases of the industry.

The series Fishery Facts documents developments in research in the fishery sciences, including biology, technology, and engineering. The publications are written by scientists and other staff members of the National Oceanic and Atmospheric Administration, National Marine Fisheries Service.

Publications in the Fishery Facts series are available free in limited numbers to governmental agencies, both Federal and State. They are also available in exchange for other scientific and technical publications in the marine sciences. Individual copies are available for purchase from the Superintendent of Documents, U.S. Government Printing Office, Washington, DC 20402. Prices appear on the title page of each publication.



U.S. DEPARTMENT OF COMMERCE

Peter G. Peterson, Secretary

NATIONAL OCEANIC AND ATMOSPHERIC ADMINISTRATION

Robert M. White, Administrator

NATIONAL MARINE FISHERIES SERVICE

Philip M. Roedel, Director

# FISHERY FACTS-4

## inshore lobster fishing

JOHN T. EVERETT

NMFS Extension Publication

SEATTLE, WA

October 1972

For sale by the Superintendent of  
Washington, D.C., 20402 - Price



Government Printing Office

# CONTENTS

INTRODUCTION	1
NOMENCLATURE	1
LOBSTER POT CONSTRUCTION	2
The Half-Round (Semi-Cylindrical) Pot	3
The Rectangular (Trapezoidal) Pot	5
Funnels for the Half-Round and Rectangular Pots	7
The Square (Rectangular) Pot	9
ROPE AND BUOYS	16
Pot Line Attachment	16
Trawls	17
Buoys	18
BAIT	19
BOAT AND OTHER EQUIPMENT	20
FISHING METHODS	21
COSTS	22
REGULATIONS	23
ACKNOWLEDGMENTS	26
BIBLIOGRAPHY	26



# INSHORE LOBSTER FISHING

JOHN T. EVERETT<sup>1</sup>

## INTRODUCTION

Lobster (*Homarus americanus*) fishing is a common activity along the Northeast coast of North America from Labrador to the Carolinas. The size of individual inshore fishing operations ranges from "non-commercial" fishermen with one or two traps to large commercial operations involving 2-4 men with 700 or more traps. In 1969, 31.6 million pounds of lobsters worth \$26.6 million were taken by the United States fishermen. This catch rate is very close to the previous 5-year average. In 1967, over 1 million traps were used to land 87 percent of the total catch with most of the remainder landed by otter trawlers.<sup>2</sup>

## NOMENCLATURE

Lobster traps are also known as pots; the two words are used interchangeably, although the latter is more common in the lobster industry. Pots consist of a compartmented apparatus designed to attract, catch, and hold lobsters.

Nearly all modern pots consist of one or two funnels (heads) through which a lobster enters the chamber compartment (commonly called the "kitchen") in search of the bait. Once the lobster finishes eating, it apparently can see no other easy way out and moves through a second funnel into a "parlor" compartment which, if properly constructed, will hold it permanently. Where there is a great abundance of lobsters, some fishermen will use pots

---

<sup>1</sup> Staff Specialist, Technical Advisory Division, National Marine Fisheries Service, Washington, DC 20235.

<sup>2</sup> *Fisheries of the United States . . . 1969*, Frances Riley, Division of Statistics and Market News, Department of Interior, Fish and Wildlife Service, Washington, D.C., March 1970.

which have two parlors with the baited chamber compartment between them.

Bait consists of whole fish, fish trimmings, specially processed and packaged fish, or other organic matter which will serve to attract lobsters. Bait is placed in the trap and secured in bait bags (bags made with netting), in bait boxes, on metal or wood rods, on hooks, or under a heavy rubber band.

Pot construction is normally of wood (oak is favored), but plastic, wire, aluminum, and plastic coated wire are also used. The pots are ballasted with bricks, rocks, metal, or cement.

Pots are fished singly or in trawls (groups of from two to over fifty tied together in a string). The end pots of a trawl, and all pots fished as singles, have a rope leading to a buoy on the surface.

The buoys are painted with the owner's colors, which are generally registered with the State and also, depending on the State's law, the buoys might carry a registration number, owner's initials, or owner's social security number. The owner may also choose to number his pots. State regulations are discussed in the last section, "Regulations", of this paper.

## **LOBSTER POT CONSTRUCTION**

Lobster pots are often bought already built from manufacturers. These manufacturers also sell the pot stock precut and bundled in kit form ready to be assembled. Each manufacturer has his own favored style of pot, but will build other styles and also will generally custom build pots for fishermen. The experienced fisherman will often modify manufactured pots to meet his own specifications, especially in regard to the distances between laths, size of net mesh in corners of funnels, and also the hanging of the funnels.

Some metal and plastic pots are collapsible and can be transported aboard boats in greater numbers in comparison to rigid types.

In some areas, most fishermen build their own pots while in others pre-built or semi-built pots are more common. The decision of whether to buy or build is generally based on the individual fisherman's time available during the off-season.

Three basic types of wood lobster pots are recognized by their geometric shapes. The common names do not reflect the true geometric shapes. The construction of the three types are described as follows:

## The Half-Round (Semi-Cylindrical) Pot<sup>3</sup>

The half-round pot (Figure 1) is the most difficult type to build because the framing is steamed and bent to shape by the builder.

The base is about 32" long by 27" wide; the height is about 18" (all outside measurements). Each pot requires three bows. The bow is made from a board 47" long by 1 $\frac{1}{8}$ " wide by  $\frac{1}{2}$ " thick. Each end of this board is turned or whittled to form a cylindrical pin 2" long by  $\frac{1}{2}$ " diameter. Three sills are made from boards 27" long by 1 $\frac{1}{2}$ " wide by 1" thick. Two holes,  $\frac{1}{2}$ " in diameter, are drilled through each sill, centered 2 $\frac{1}{2}$ " from each end.

The board for the bow is steamed and bent into the shape of a U, and the cylindrical pins are inserted into the holes in the sill so that they project 1" beyond the sill.

To complete the frame of the pot, two runners are made from boards 32" long by 1 $\frac{1}{2}$ " wide by 1" thick. Each runner is drilled with three  $\frac{1}{2}$ " diameter holes to receive the projecting pins of the

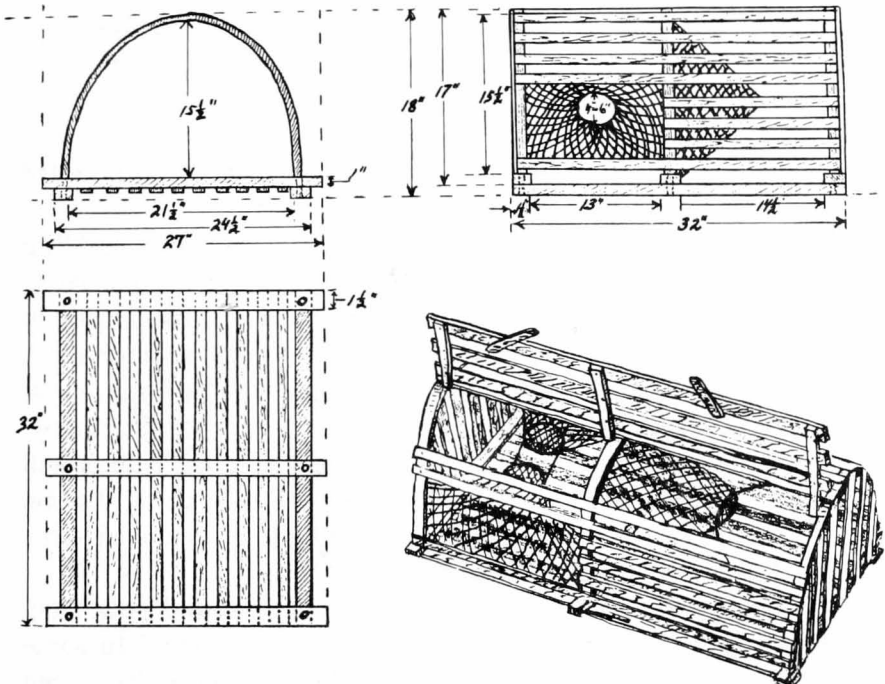

1—Half-round lobster pot.

<sup>3</sup> Fishery Leaflet 64, *Construction and Operation of Lobster Fishing Gear*, Frank E. Firth, U.S. Department of the Interior, Fish and Wildlife Service, Reissued January 1950.



bows. Two of the holes are centered  $\frac{3}{4}$ " from one end. The three bow-and-sill sets are then fastened to the runners by slipping each pair of pins projecting through the sills into the corresponding holes in the two runners and driving galvanized nails through the sills and runners into the pins of the bows.

Common building laths, usually  $1\frac{1}{8}$ " wide by  $\frac{3}{8}$ " thick, are nailed to the sills, bows, and ends, except where the door and the entrance funnels are to be installed. The laths are spaced approximately  $1\frac{1}{8}$ " apart. The door to permit access into the pot is made of three laths fastened to the three cleats of the correct curvature. Hinges formed from leather, rubber straps, wire, or twine hold the door in a longitudinal position across the pot near the top of the bows.

The center bow divides the pot into two sections of slightly different sizes. The shorter section is called the kitchen. The lobster, seeking the bait, enters the chamber section first, and then swims into the larger section, or parlor, where it is trapped.

The kitchen, or shorter section, is usually provided with an entrance on each side. The openings start about  $2\frac{1}{2}$ " above the floor of the pot, and are about 8" high by 13" long. Each is provided with netting to form a funnel about 7" deep which ends in a ring 4" to 6" in diameter. Two or three brace lines tied between the two rings draw the netting taut to form two rigid funnels. The inner funnel or "long head" is then lashed or nailed to the middle bow and tied into position.

The completed pot is weighted with two to four common building bricks which are distributed evenly on the floor of the pot so as to maintain its balance. Laths are nailed around the bricks to hold them in place, or else they are fastened with wire or cord. This pot could also be ballasted with cement as in the square pot, which is described on the following pages. When the pot is new, and at the beginning of each season thereafter, extra ballast will be needed until the pot becomes thoroughly water-soaked. Large, flat stones are often used for this purpose and are removed after the pot has been under water a few days.

The dimensions and construction of the half-round pots vary considerably. The pots may be from 28" to 48" long. In some localities, the outer heads are often made of wooden laths, wired together to form a funnel. A few pots even have the inside funnel replaced by a vertical, self-closing, lath door that traps the lobsters in the parlor. Some pot builders fashion bows from spruce saplings which they smooth and bend into shape.

## The Rectangular (Trapezoidal) Pot<sup>4</sup>

Rectangular pots have the most rugged design. They vary considerably in construction details and range from 30" to 42" in length. A typical rectangular pot is illustrated in Figures 2 and 3. It is 32" long by 22" wide and 15½" deep (all outside measurements).

In structure, the rectangular pot is similar to the half-round pot except that the three bow-and-sill sets are replaced by three frames made from straight boards. The sides of each frame are 1" by 1" boards about 15½" long with the ends turned or whittled to form cylindrical pins ½" in diameter. The pin at the upper end is 1" long; the lower pin is 2" long. The top and bottom sills for each frame are 22" and 26" long, respectively. These are made from stock 2" wide by 1" thick in which, approximately 1" from each end, holes are drilled to receive the dowels of the sides. Since the sills are unequal in length, the sides of the frame slope, and either the holes or the pins must be cut on an angle. After the

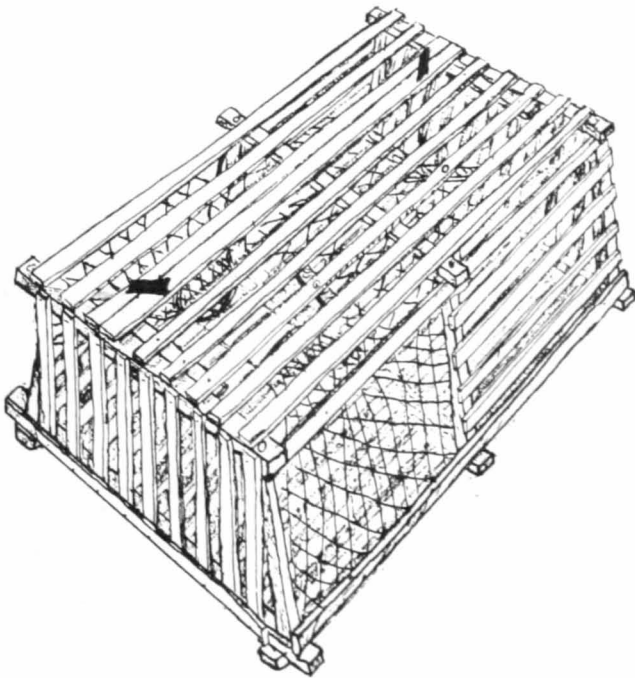

2—Rectangular lobster pot.

<sup>4</sup> Ibid.

dowels of the side frame members are slipped into the holes in the sills, the frame is complete, and the lower pins project about an inch beyond the lower sill. The protruding pins serve to fasten the frames to the runners.

Two boards 32" long, made from the same stock as the sills, are used for runners. Three holes for receiving the pins are drilled about 1" from each end of the runner, the third hole 15" from one end. These holes should be bored either vertically, or at an angle, depending on the construction of the pins.

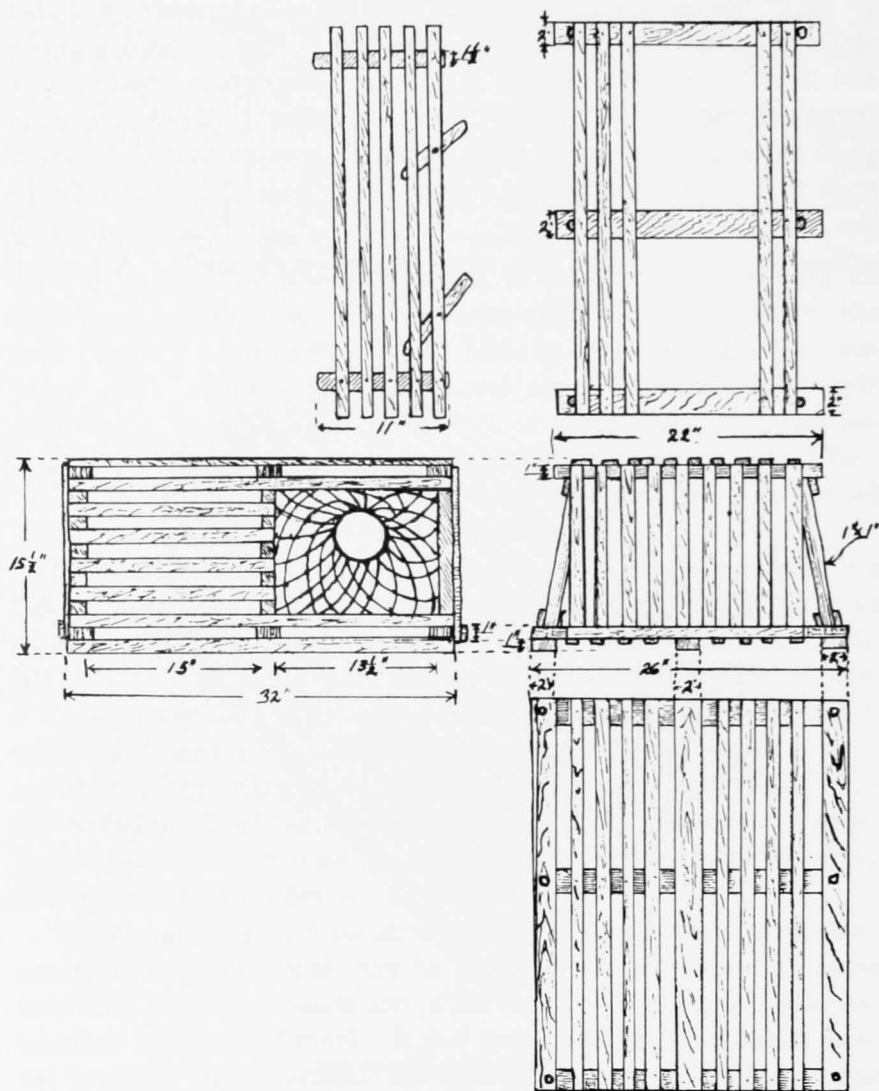

3—Rectangular lobster pot.

The three frames are fastened to the runners by slipping each pair of projecting pins into the corresponding holes in the two runners. Galvanized nails are then driven through the sills and runners into the pins in order to secure the joints. A third runner, without holes, is nailed to the bottom sills between the other two runners. Laths,  $1\frac{1}{8}$ " wide by  $\frac{3}{8}$ " thick, are nailed about 1" apart to the sills and uprights, except where openings are left for the door and entrance funnels. Weighting and the fitting of openings are similar in half-round and rectangular pots.

### Funnels for the Half-Round and Rectangular Pots

Figures 4A, 5A, and 6A, respectively, show how the  $3\frac{1}{4}$ " and the 3" mesh (stretched measure) outer heads and the 3" mesh

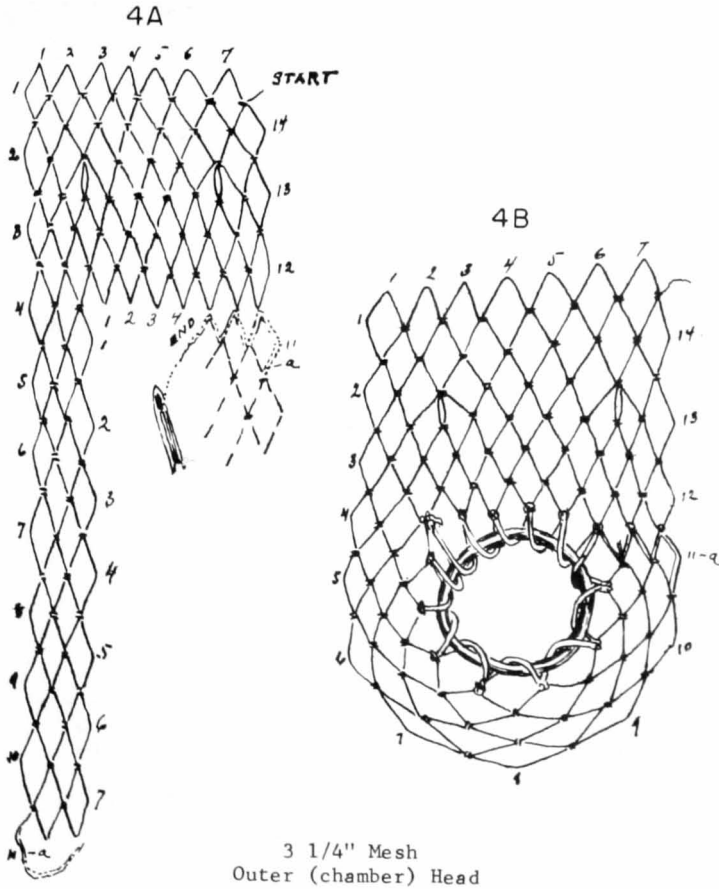

4—Method of knitting webbing used in lobster pot head construction.

inner head are knitted into the shape of an inverted L. Outer heads could be cut from two pieces of webbing properly joined, and the inner head from a single piece of webbing if desired. Fig-

5A

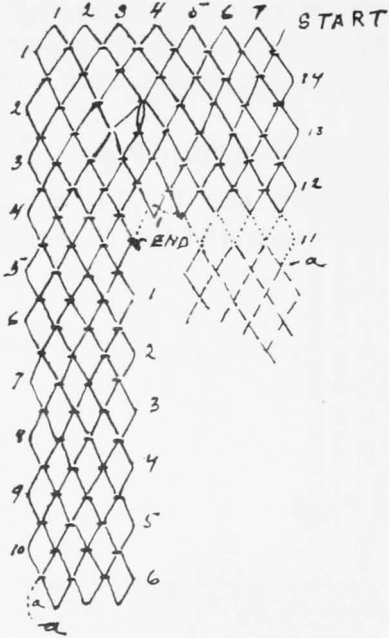

6A

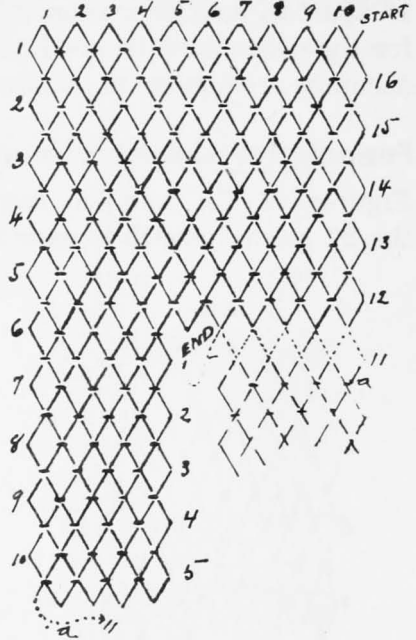

5B

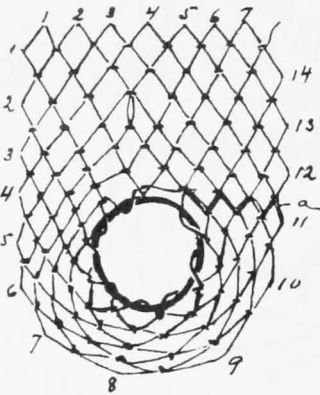

3" Mesh  
Outer (chamber) Head

6B

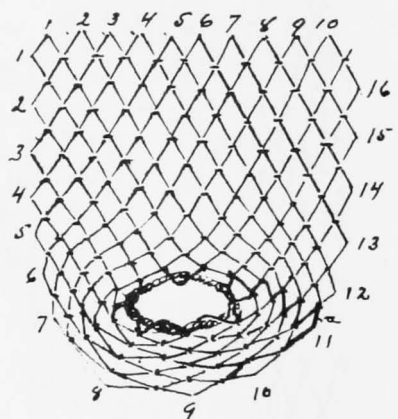

3" Mesh  
Inner ("parlor") Head

5-6—Method of knitting webbing used in lobster pot head construction.

ures 4B, 5B, and 6B show how the vertical leg is bent to fit the entrance ring. The dotted lines show the attachment of the vertical leg to the horizontal leg.

Figure 4B also illustrates how the ring is fastened to the completed  $3\frac{1}{4}$ " mesh webbing by "mending." The double lines show the method of knotting the twine to form the half-meshes that hold the ring. However, in Figure 5B, the completed 3" mesh webbing is fastened to the ring by "lacing." The lace is finished with one knot which corresponds to the point marked "end" in Figure 5A.

Metal or wooden rings, 4" to 6" in diameter, are used in the outer heads; however, as shown in Figure 6B, the ring in the parlor head is made from a 6 or 9-thread rope which is reeved through the meshes and tied to form a circle about 4" in diameter. The finished parlor head is nailed or laced to the middle bow or frame. Two brace lines, tied from the sides of the ring to the bow or frame at the end of the parlor, draw the netting in to form a taut funnel and at the same time stretch the ring to an ellipse about 5" or 6" long. This narrow, horizontal opening, illustrated in Figure 1, is flexible enough to permit entrance by the lobster, but makes its escape almost impossible.

## **The Square (Rectangular) Pot**

The square pot is widely used because it is fast to build, lightweight, and takes up much less room on the boat. The design which follows should be simple for the amateur to build. Figure 7 depicts the completed pot.

Material for 1 (one) 32" pot:

- 21 Laths —  $1\frac{1}{2}$ " by  $\frac{3}{8}$ " by 32"
- 2 Runners —  $3\frac{1}{2}$ " by  $\frac{5}{8}$ " by 32"
- Framing — 6 pieces  $1\frac{1}{4}$ " by 1" by  $9\frac{1}{2}$ "
- Framing — 6 pieces  $1\frac{1}{4}$ " by 1" by 20"
- 3d, 6d, 8d nails (galvanized)
- 17 cleat size laths  $1\frac{1}{2}$ " by  $\frac{3}{8}$ " by  $11\frac{1}{2}$ "
- A piece of Rubber Tire

NOTE: Maximum distance between laths —  $1\frac{1}{4}$ "

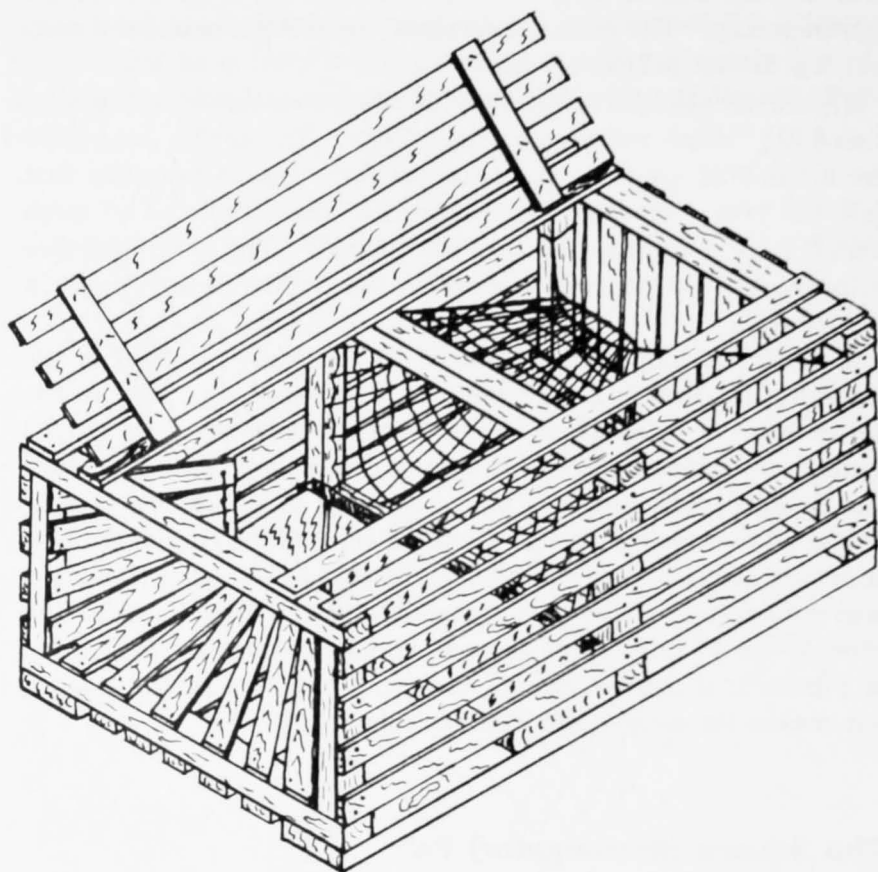

7—Square pot.

Step 1. Assemble 3 frames

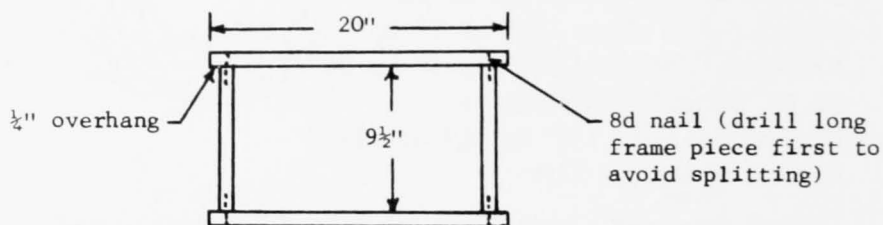

8—Square pot frame construction.

Step 2. Attach cleats to frames (must be flush on outside edges and ends)

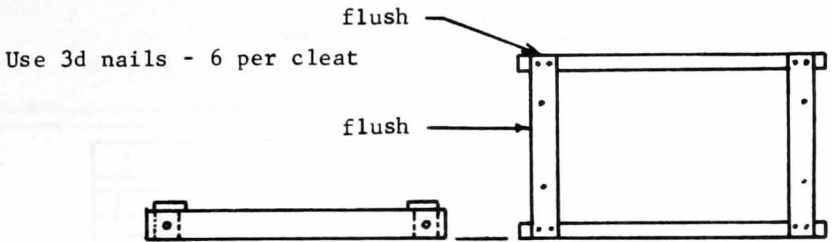

9-Square pot cleat attachment to frame.

Step 3. On center frame (choose one) drive 4 8d nails one inch deep into long piece for cement support and one 8d nail into each side piece of center frame one inch from the bottom for bait band.

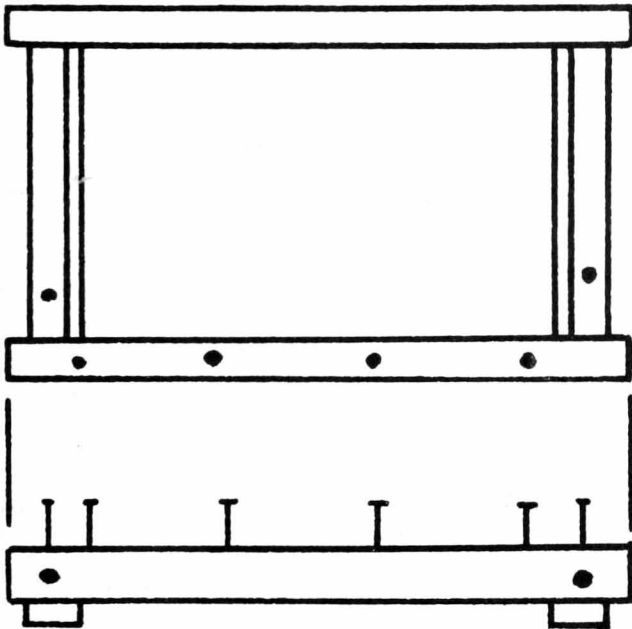

10-Square pot center frame.



Step 4. Set up 3 frames on flat surface and fasten runners to frames with 6d nails. Space out 5 laths evenly and fasten with 3d nails.

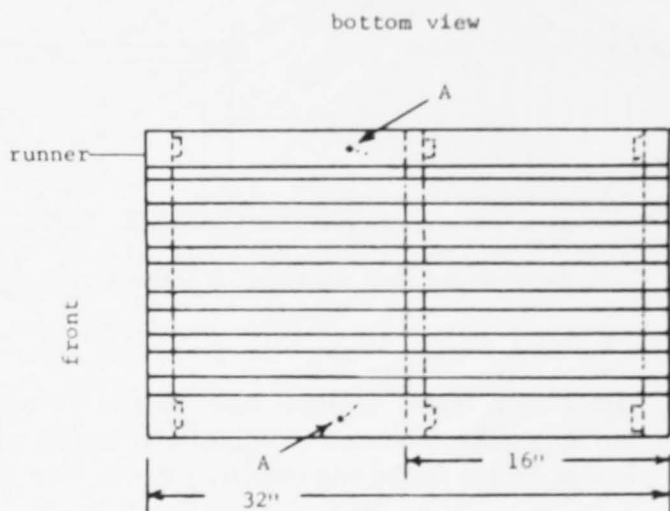

11—Square pot bottom construction.

6" forward of center frame, drive two 8d nails into the pot through the runners (A). Bend slightly inward (for cement support)

Step 5. Turn pot top side up and nail 4 laths on top leaving an 11" opening for the door.

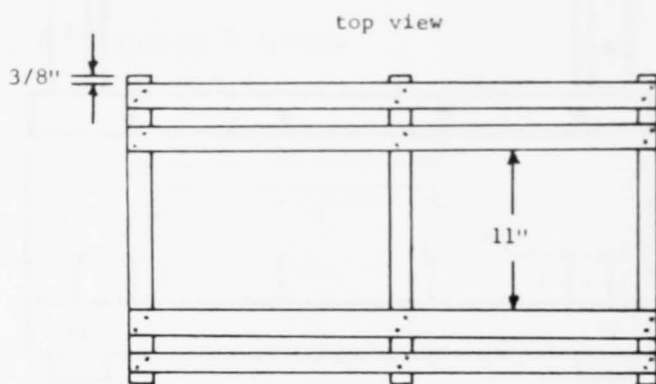

12—Square pot top construction.

Step 6. Nail 4 evenly-spaced laths to each side.

Step 7. Insert folded sheet of newspaper under cement support nails and 1" up side.

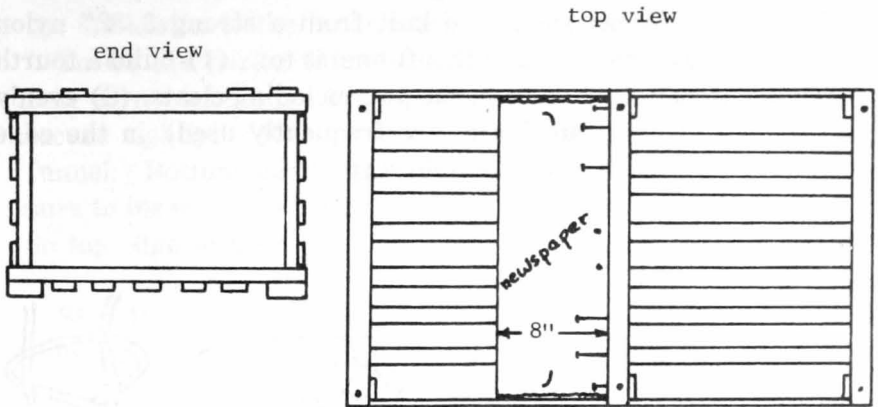

13—Square pot side construction — end view.

14—Preparation of square pot for cement.

Step 8. Mix about one gallon of cement and apply to newspaper area, filling front floor of pot forward for 8" and 1 1/4" deep. Insert two 8d nails point up in cement at 1" forward of the center frame. As cement sets up, imprint initials or other identification in cement. Let harden at least three days before pounding on pot.

Step 9. Build front funnel as follows: Take lath pieces and cut or whittle to form a funnel 8" deep.

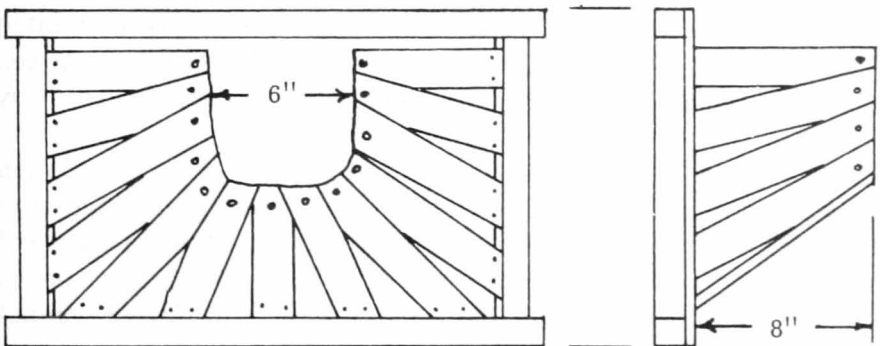

15—Square pot front funnel construction.

Nail to inside surface of frame and form funnel shape by threading copper wire through a drilled hole in the end of each adjacent piece and making a half-hitch with wire after the threading of each hole. The top piece on each side should run parallel to the top lath but not more than 1½" below it.

The parlor funnel should be knit from a strong 3/32" nylon twine. An easy way to build this funnel is to: (1) build a fourth frame identical to the three in the pot, including cleats, (2) evenly space hooks (coffee-cup hooks are frequently used) in the edge of the frame as shown in the following:

Note: all hooks face out

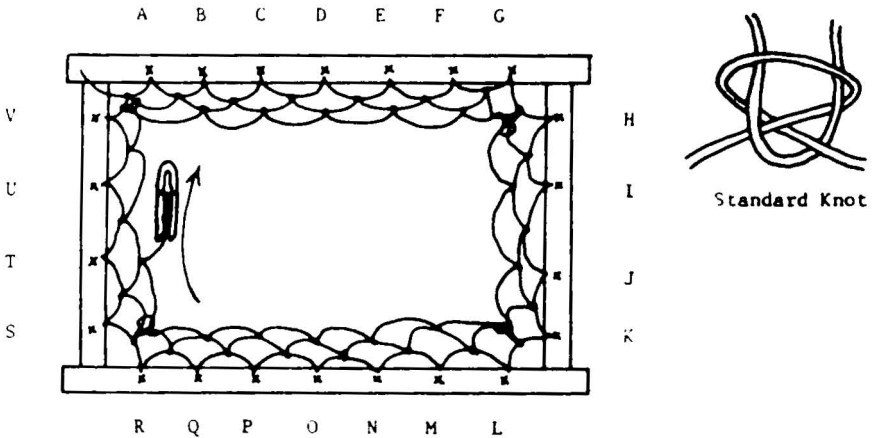

16—Construction of square pot parlor funnel.

(3) fill standard net knitting needle (bobbin) with twine, (4) place frame between knees, (5) place clove hitches on all hooks starting at A leaving a 2" tail piece of twine before first hitch (leave enough slack to allow twine about ½" deflection between hooks), (6) once all hooks are done, start second revolution by tying standard knitting knot in the middle of the 2" piece prior to A, then continue between AB then BC, etc., knit full revolution making a 1¼" mesh size, (7) at VA take in the corner two meshes as one (do this in each corner as they are reached in the course of knitting revolution), (8) on the fourth revolution do not take in at all, but on the fifth take in at corners KL and RS, (9) do not take in any more but continue until there are 10 knots in a line going from G towards you to the left (stop at G).

Place 3d nails in the center frame of the lobster pot corresponding to positions of the hooks on the pattern frame but located on the inside edge. Remove net from pattern frame and insert in pot on corresponding nails. Bend nails over. An alternate method is to lace split laths through the first row of meshes and nail the split laths to the inner surface of the center frame.

To tie the parlor funnel in place, run twine from each upper rear corner of the pot to the corresponding side of the funnel and secure tightly. Weave twine through upper and lower ends of funnel. Bottom should be tight, but top should rise without pressure to insert a man's vertical fist. Attach a small piece of weight on top edge to keep the funnel closed.

Step 10. Fasten 8 cleat-size laths to the back of the pot, vertically and evenly spaced.

Step 11. Build door using 4 full laths and two cleat-size laths and attach tire rubber hinges, 1" by 4", as shown:

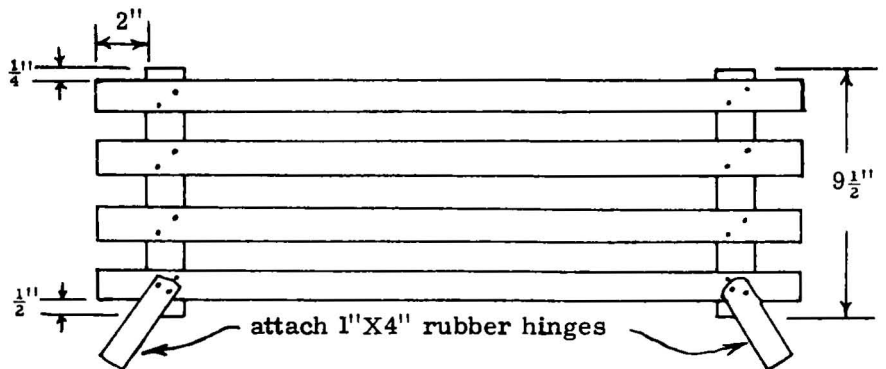

17—Square pot door construction.

Step 12. Insert a rubber band (cut from automobile tube) on the two 8d nails provided at the lower front of the center frame.

Step 13. Place the door evenly on the pot and nail the hinges to the pot.

Step 14. Use a cleat-size lath as a latch. Use a 6d nail and a piece of leather or rubber as a washer and nail it to the middle frame on top of the lath nearest the door opening.

## ROPE AND BUOYS

### Pot Line Attachment

Lobster pots are usually tied to a surface buoy with a  $\frac{1}{4}$ " to  $\frac{3}{8}$ " diameter nylon or other synthetic rope. The rope should always be 10 to 20 percent longer than the water is deep at high tide.

The rope is fastened to a corner of the pot or is connected to a bridle tied to each side of the lobster pot end. The bridle arrangement will generally haul easier through the water.

It is immaterial whether the rope is tied to the chamber or to the parlor end. Some fishermen theorize that a swaying rope at the chamber end will frighten away lobsters. Others maintain that a rope tied to the parlor end will allow some lobsters that may still be in the chamber compartment to escape during hauling.

Typical acceptable rope and buoy arrangements are shown in the following diagram:

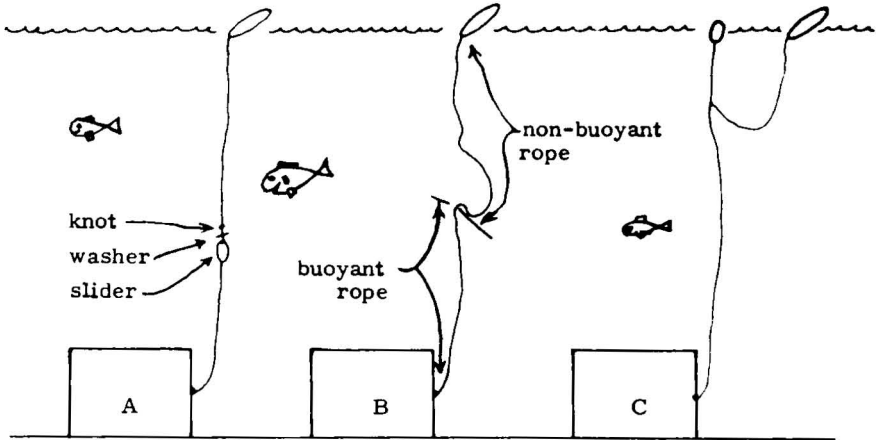

18—Acceptable rope and buoy arrangements.

Arrangements A and B permit the easiest operation. In A, a slider of cork, wood, plastic, or plastic foam keeps the rope off the bottom. The slider is restrained from surfacing by an overhead knot set at about 2 fathoms but slides to the pot permitting hauling without removal from the davit or pot hauler. In warm waters a washer made from a rubber tube or tire serves to protect the knot from cutting on barnacles which will grow on the slider buoy.

In arrangement B, 30 to 50 percent of the line consists of buoyant synthetic rope which serves to keep the line off the bottom.

The buoyant and non-buoyant pieces are spliced or tied together.

In arrangement C the rope is kept off the bottom by a bobber which is tied to the main rope. The bobber should have a 5' rope between it and the main line to reduce chances of a passing boat cutting the main line.

Some unsatisfactory rope and buoy arrangements are shown in the following diagram:

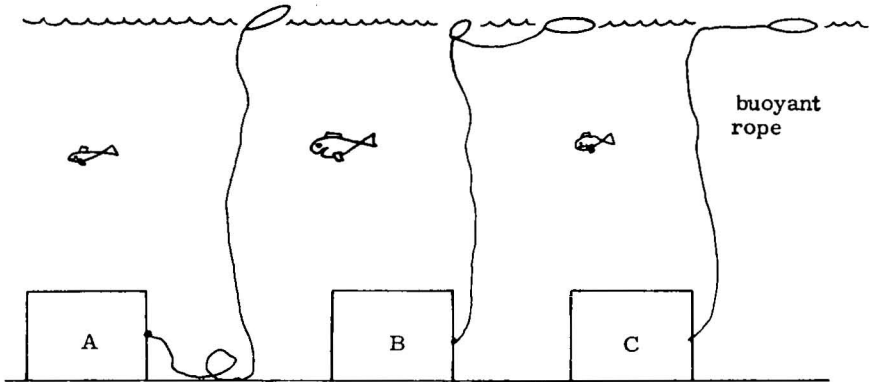

19—Unsatisfactory rope and buoy arrangements.

In A the rope lies on the bottom where it will likely chafe or get caught in rocks. In B any boat passing between the bobber and buoy would probably sever one or both lines. In C the buoyant rope rises to the surface where it is vulnerable to damage by passing boats.

In some localities pots are protected from boat traffic or poachers with a device which keeps lines submerged for a period of one or more days. The device releases the buoy when a chemically active portion of the restraint system dissolves in sea water. Most situations do not justify the expense of such restraint systems and they are not used in the majority of operations.

## Trawls

In some locations the sea bottom as well as the abundance of lobsters make it feasible to use a number of pots tied together in a string. Depending on the size of a boat, bottom conditions, tidal effects, and boat traffic, the number of pots in a trawl will range from 2 to over 50.

The pots are generally spaced from 10 to 20 fathoms apart, depending on the abundance of lobsters and water depth. Only

the end pots in a trawl are equipped with surface buoys and these are affixed in the normal manner.

## Buoys

The buoys used for lobster fishing range from empty bleach bottles or wood, to plastic floats equipped with small pennants.

Some fishermen feel that it is best to have buoys that are not easily seen, thus protecting themselves from poachers. Most, however, find that a highly visible buoy will speed up hauling operations by reducing the time spent looking for the pots. A second advantage of easy-to-see markers is that other boat operators can spot and steer around them. This greatly reduces the loss rate.

The type of buoy is up to the discretion of the fishermen except where regulated by law. Generally, the best buoys are those manufactured for the purpose. These are typically molded from any of several types of plastic foam. They come with a hole through the center axis through which a stick is placed. A rubber strap for fastening the buoy is nailed to one end of the stick. The buoy is positioned and retained as close as possible to this end of the stick with a rubber washer.

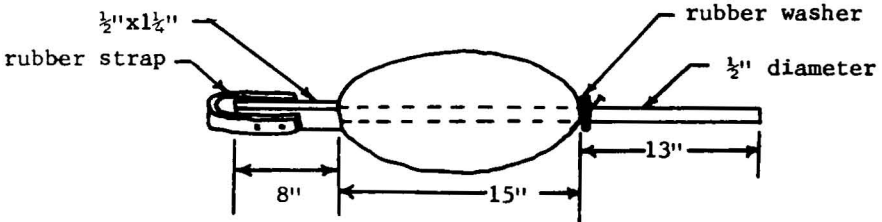

20—Buoy assembly.

The straps and washers can be purchased or cut from rubber tires. The hole in the washer is sometimes cut with a sharpened 5/8" steel pipe pressed through the material with a large bench vise.

Buoy paint is produced by many paint manufacturers, but good quality oil base paints will also prove satisfactory. It is to the advantage of the fisherman to keep his buoys in good condition and well painted.

Buoys must carry some identification of the owner in addition to his color scheme. Normally, this is just his initials but in some States, the social security number or its last four digits, or lobster

license number may be required. This identification can best be placed on the buoy with a branding iron. The branding irons (some are electric) are available from various manufacturers.

## **BAIT**

The most common baits used to catch lobsters consist of industrial grade fish (herring, mackerel, skates, etc.) or waste from processing.

In many places the bait must be fresh or of a hard textured species in order to withstand the attacks of small fish, starfish, urchins, and sand fleas. In other places or times the softer baits can be used.

When necessary, bait can be preserved by salting, and depending on species and temperature, 50 lb. or more of salt per 55 gallon drum may be required. With cool weather, half this amount should be sufficient.

In the heat of summer, only refrigeration or ice can do a satisfactory job of preserving the bait.

Bait is obtainable from fish processors, fish dealers, fish trap operators or it can be caught by the fisherman. Often bait is very hard to come by and can be very expensive.

Bait can also be purchased in the form of processed fish which has been packaged in small burlap purses. Many fishermen question its effectiveness when compared to more common sources of fish, but it is easily stored and when nothing else is available, it is used effectively.

One of the fastest methods of baiting involves just placing the bait under a rubber band on the floor of the pot. If the rubber band is used, it is helpful to have some small spikes sticking up in the floor of the pot to prevent the bait from sliding around. The bait also may be placed on metal or wood rods which run from the floor of the pot to the top. A third method is to use hooks made of wire. These hooks, which are like safety pins, are suspended from the central frame of the pot with the fish hanging in front of the parlor funnel.

A fourth method is to place the bait in purses (bait bags) which are also hung from the front of the center frame. The purses are normally made of netting with a  $\frac{1}{2}$ " to 1" mesh and are useful in protecting the bait in areas where small fish are apt to eat it. The purses also serve well when the bait being used is small or soft fish. The use of purses generally requires more time in baiting the pot.



## BOAT AND OTHER EQUIPMENT

The size of the boat to be used depends on the needs of the fisherman. A small rowboat would serve to haul pots in front of one's house, but for a commercial operation something more seaworthy and roomy is required.

A part-time fisherman should have a fast boat, about 18-26 feet long. A full-time fisherman should have a boat 26-32 feet long if he is hauling mostly single pots or short trawls. If longer trawls are to be used and two men will crew the boat, the size should range from 30 to 50 feet.

In a small boat powered by an outboard motor, the pots can be hauled by hand or with a motor-driven winch manufactured for the purpose. In larger boats, winches are powered from the main engine through belt, chain, or hydraulic drives. V-shaped power drums called pot haulers are used on many boats. The drum is driven hydraulically with a controlled torque. The fisherman places the pot rope through the davit block and then lays it on the "V" of the drum. Through pressure and friction, the rope catches in the "V", allowing the pot to be hauled "hands-off" until it reaches the davit. On some boats the davit is eliminated by mounting the pot hauler in its place.

If the fisherman stays at sea more than a few hours, he must have a method of keeping the lobsters alive. This is generally done by pumping seawater through a tank or barrel containing the lobsters. If the water stops circulating, the lobsters will consume all the oxygen and die.

The boat must have a platform on which to place the pot when it is hauled. This generally consists of a box or half barrel which also contains bait. The pot is balanced on the container and the rail of the boat.

The boat will be rigged for starboard or port-side hauling, depending on whether the fisherman is right or left-handed.

When trawls are being fished, the first pots are generally stacked aboard while the rest of the trawl is hauled and serviced. The whole trawl is then moved to a slightly different location and each pot is set as the rope being payed out becomes taut. Some boats have a special bench which is level with the stern where the pots can be placed after hauling. During setting, the first pot is pushed over and as the rope becomes taut it pulls the next pot off the stern. This continues until the last pot and buoy-line reaches the water. If a trawl fishes extremely well, the fisherman will try to set it

back in the same area he hauled it from. Lobstering with trawls is dangerous because of the rapid paying out of lines and the high tension in the lines when a snarl occurs.

## FISHING METHODS

The pots are normally set out in the early spring and brought ashore by the start of winter. In some localities fishing is possible all winter, weather permitting.

Pots are allowed to set one, two, or three nights, depending on the rate of deterioration of the bait and the number of pots a fisherman has. A typical fisherman might have two sets of traps, lift one set each day, and perhaps take the third day off to purchase bait, sell his lobsters, or perform maintenance or repairs.

Many fishermen sell their catch every day, while others store their lobsters in holding cars or crates until they have accumulated a certain number or until it is convenient to sell. The cars or crates, which consist of little more than slatted boxes with a cover, are floated or sunk at the boat mooring or other convenient places.

Since the wind does not blow as hard during the early morning hours, it is advisable in some localities that a lobsterman get a very early start. When the sea is calm, and if the pots are not spread too far apart, a fisherman can haul about 18-22 pots per hour. If pots are arranged in trawls, the rate can be doubled.

As lobsters are caught, the fisherman must measure them to see if they are of legal size. To do this, he uses a gage which is set at the State's minimum legal size. One end of the gage is inserted in the lobster's eye socket and the other end extends along the back of the carapace. If the carapace extends beyond the edge of the gage, the lobster is of legal size.

In some localities, there is a maximum legal size for lobsters; lobsters kept must not be larger than a second gage. This is done in the belief that these large lobsters provide breeding stock. The weight of a small legal size lobster ("chicken" lobster) is about  $\frac{7}{8}$  to 1 pound. A  $1\frac{1}{4}$  pound lobster is a "quarter" and from  $1\frac{1}{2}$  to  $2\frac{1}{2}$  pounds, it is a "select." At about 3 pounds the price per pound begins to decrease. Over 5 pounds, the lobster is generally called a "jumbo." If less than the legal size, the lobster is a "short."

Those lobsters with only one claw are called "culls", and those with no claws are called "pistols." Culls and pistols generally

bring 10-30 percent less in price. Some dealers refuse to handle pistols.

As soon as the lobsters are removed from the pots, the fishermen will generally put wooden or plastic pegs (plugs) in each claw joint, or he may put a rubber band around each claw. Either of these methods serves to prevent lobsters from damaging each other. Some men peg or band only the crusher claw and some do neither. The rubber band method is preferred because it does not injure the lobster and infections are less likely to happen.

In many waters, pots are subject to barnacles and teredo worms. Chemical treatment may be used to retard these parasitic organisms. These chemicals are available commercially, but it is probably easier to use vinyl coated wire pots or pots of other non-wood construction.

Barnacles will grow on most chemically coated wood and on non-wood pots. Since they should be killed at about the same frequency as teredo worms, the standard oak pot maintains its competitiveness.

In order to kill the barnacles and teredo worms, the pot must be taken ashore and dried for about four days. If the pot is well cared for and not lost to boat traffic or storms, it will give many years of service.

## **COSTS**

Some of the costs that are encountered by a lobster fisherman are (approximately):

<i>Item</i>	<i>Cost in dollars</i>
License fee	5 - over 100
Bait (55 Gallon drum)	6 - 10
Wooden Pot Stock (framing, laths)	2.80
Wooden Pot Kit (framing, laths, nets)	4.40
Wooden Pot (built)	7.50
Aluminum wire on steel frame pot-coated with PVC (built)	25.00
Rope (12 fathoms)	1.50
Buoy	.65
Buoy Stick	.15

Other important items of costs include fuel, equipment, repairs, and dockage.

## REGULATIONS

Lobster fishing regulations are maintained and enforced by the States. They vary from State to State and must be checked prior to engaging in any fishing. Items regulated by various States include:

1. Number of pots an individual can fish.
2. Lobster fishing season as well as hours of day.
3. Colors and markings on buoys and pots.
4. Size of lobsters to be taken as well as prohibition against taking egg-bearing lobsters.
5. Display of buoy or buoy color on boat.
6. Prohibition against wooden buoys and bleach bottles.
7. Fishing license and boat registration.
8. Use of pot trawls.
9. Molesting of lobster fishing gear.
10. Spacing between laths to allow escape of small lobsters.
11. Means to allow escape of lobsters if pot is lost.

Since lobster pots are often lost, fishermen should equip their pots with a means to allow the trapped lobsters to escape after some period of time even if not required by law. One of the better ways to achieve this is to have one or more of the lower laths on the side of each wooden pot made from a soft wood. The lobster is able to destroy this wood after a few weeks and achieve its freedom. In a pot made with metals or plastics, it is possible to use a portion of iron wire which will eventually rust out and permit escape.

Figure 21.—Scenes aboard a lobster boat.



A. 32' lobster boat at mooring.



B. Steaming to lobster pot.



D. Placing rope over davit (note hydraulic pot hauler).

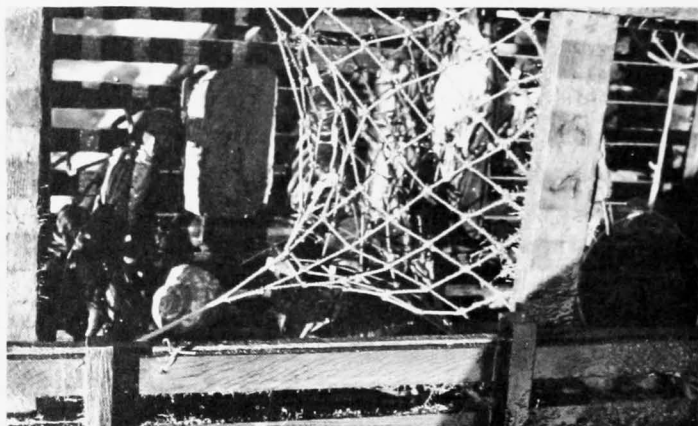

F. Pot on deck showing caught lobsters and conch.

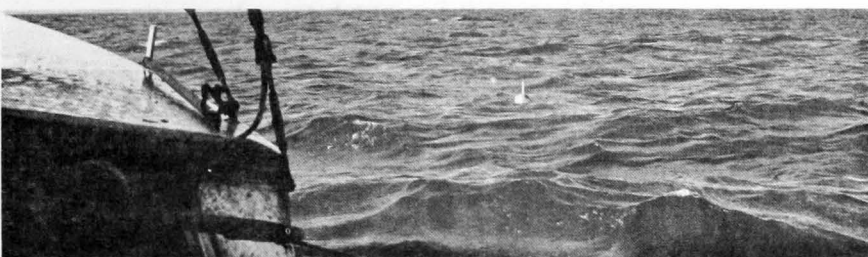

C. Approaching lobster pot.



E. Pot being hauled "hands-off."



G. Removing lobsters from pot.

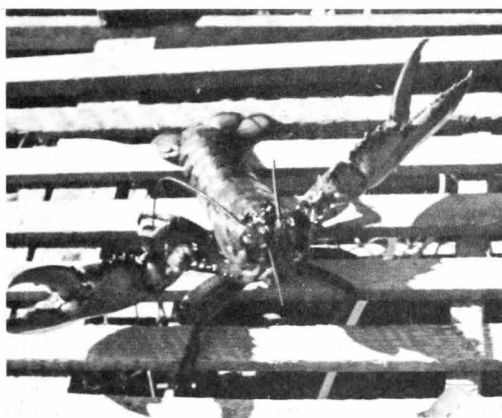

H. Freshly caught angry lobster.

## ACKNOWLEDGMENTS

Thanks are extended to Mr. M. R. Greenwood of the National Marine Fisheries Service (NMFS), Washington D.C. Office, and to Mr. Ernest D. McRae, Jr., of the NMFS Northeast Fisheries Center for their excellent suggestions which have been incorporated in this paper.

Photos used in this document were taken aboard the lobster boat owned and operated by the author's father, John R. Everett, in Fairhaven, Massachusetts.

## BIBLIOGRAPHY

Dow, Robert L., *The Story of the Maine Lobster*, the Department of Sea and Shore Fisheries, Augusta, Maine, July, 1949.

Firth, Frank E., Fishery Leaflet 64, *Construction and Operation of Lobster Fishing Gear*, U.S. Department of the Interior, Fish and Wildlife Service, Washington, D.C., Reissued January, 1950.

Riley, Francis, *Fisheries of the United States . . . 1969*, Division of Statistics and Market News, Department of the Interior, Fish and Wildlife Service, Washington, D.C., March, 1970.

Scattergood, Leslie W., *The American Lobster, Homarus Americanus*, Biological Laboratory, Bureau of Commercial Fisheries, U.S. Fish and Wildlife Service, Boothbay Harbor, Maine, 1960.